

DragonflyTV: GPS Activity 13

Gotta Lava It!

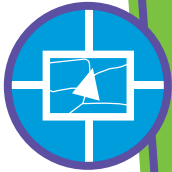

Hawai'i Volcanoes National Park
Hawai'i, HI
www.nps.gov/havo

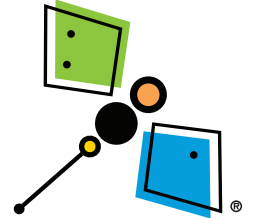

Lava Flow

We're Julia and Briana, and we live on the island of Hawai'i, where lots of lava can be found! Lava flows are unique environments. They look like a cross between the moon and a gigantic parking lot! Even though volcanoes have been erupting here for thousands of years, much of the island is full of green plants. We stopped by the Hawai'i Volcanoes National Park Visitors Center to find out how that could be. Our question: How do plants return to an area wiped out by a lava flow?

To learn more about plants growing on lava flows, a park ranger suggested we walk the Mauna Ulu flow, which was active 40 years ago. We soon spied the two kinds of lava: pahoehoe, which is smooth, and a'a, which is rough and jagged. We also noticed patches of jungle right in the middle of the flow. These patches of plants and trees, which the lava flowed around but didn't harm, are called kīpuka. We noticed three kinds of native plants in the kīpuka: kupukupu ferns, 'ōhelo berries, and 'ohi'ā trees. We decided to look for these same plants around the Mauna Ulu flow.





Icebreaker

Make a model showing how a caldera forms.



30 minutes

DragonflyTV Skill: Observing

Guide your kids as they

- 1) Carefully poke a hole in the side of the ice chest, near the bottom.
- 2) Insert one end of the tubing through the hole into the ice chest. Slide the mouth of a balloon over the tubing end in the ice chest, and secure it with a rubber band. Blow through tubing to lightly inflate the balloon, then pinch off the tubing with a clamp, with the clamp on the part of the tubing outside the ice chest.
- 3) Line the ice chest with a garbage bag, covering up the balloon. (See diagram)
- 4) Slowly (!) pour flour into the garbage bag liner, filling up the liner and chest to about the halfway mark.
- 5) Release the tube clamp, and immediately blow through the tubing, slowly inflating the balloon to about the size of a melon. Pinch off the tube and make a sketch that shows how the surface of the flour appears now.
- 6) Release the tubing clamp, allowing the balloon to deflate completely. Make a new sketch that illustrates the appearance of the flour surface now.

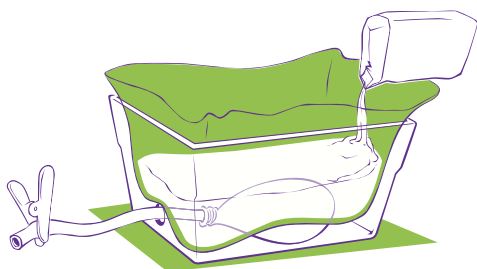

For more simple activities like this one, surf to pbskidsgo.org/dragonflytv/superdoit/index.html

▶ You'll need:

- a Styrofoam ice chest
- a plastic garbage bag (to fit in ice chest)
- plastic tubing (approx. 3/8 inch diameter, 3 feet in length)
- a small clamp to pinch the tubing
- 20 lb. of flour
- A 12-inch diameter balloon
- A rubber band

DFTV Science Helper

Calderas are large depressions near the top of a volcano. They form when a magma reservoir drains, causing the ground above the reservoir to collapse. This model shows both the swelling of the ground as the reservoir pressure builds and the subsequent collapse of the ground as the pressure is relieved.



Investigation Lava



1-2 hours

Guide your kids as they

- 1) Assemble a catapult using a spoon, wood block, 30 cm ruler and rubber bands. (See diagram.)

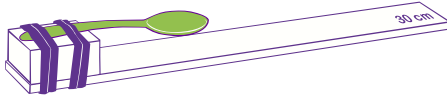

- 2) Create "tephra" of varying masses. Use a single washer for the lightest, and 4 washers taped together for the heaviest. Tape 2 and 3 washers together for the weights in between.
- 3) Locate an appropriate place to launch the catapults. Lean the catapults against a wall as shown. Set a meter stick or tape measure along the floor to measure the distance the various tephra models are thrown. (See diagram.)

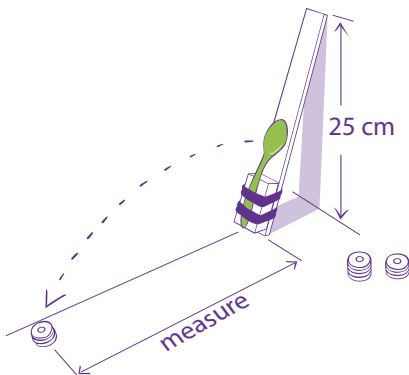

- 4) Put on safety goggles before launching anything. Use the catapult to throw each tephra sample at least 10 times. With each throw, record the approximate throwing distance to the nearest centimeter. Do not vary the launch angle or launch force (that is, how far back you bend the spoon) during the testing.

You'll need:

- rubber bands, 2 per group
- plastic spoons, 1 per group
- quarter-inch washers, 10 per group
- 2" x 2" x 3" wooden blocks, 1 per group
- tape
- 30 cm rulers, 1 per group
- a meter stick or metric tape measure, 1 per group
- goggles, 1 pair per person

DFTV Science Helper

Students build simple catapults to investigate how the mass of an object relates to how far it can be thrown by a catapult. This is analogous to how far tephra (ejected material) of different masses is thrown during a volcanic eruption. Tephra can be classified as ash, cinder (small granular debris), bombs (liquid balls), and blocks (large rock fragments).



DFTV Kids Synthesize Data and Analysis

Your kids can calculate an average throwing distance for each of the tephra samples and record the averages in a table. From there, make an appropriate bar graph.

Trial #	1-washer tephra distance	2-washer tephra distance	3-washer tephra distance	4-washer tephra distance
1				
2				
3				
4				
5				
6				
average				

DFTV Adult Tip

You might consider using other objects for your tephra, such as rice or cereal grains of various sizes, or Styrofoam peanut chunks. If you introduce something lightweight enough and of low density, students will observe how the phenomenon of air resistance becomes a factor for tephra ash particles.



Keep Exploring!

Use a stomp rocket launcher as another way to explore how far tephra debris is thrown. Put a tissue paper wad into the nozzle of the launcher, with grains of rice or cereal pieces on top of that. Give the launcher a good stomp, and track where the rice or cereal lands. How does the mass or size of the particles relate to how far they go?