

A NASA/DESIGN SQUAD CHALLENGE

ON TARGET

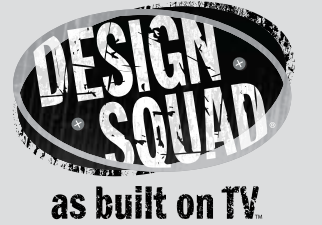
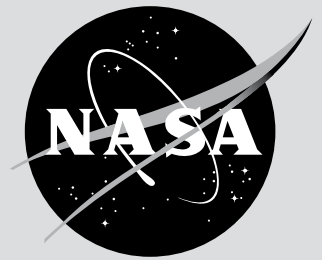

Thanks to NASA, the moon is getting a new crater! NASA is sending a spacecraft hurtling into the moon's surface. Why? To see if there's water below the surface. This collision will send up a plume of dust and gas over 6 miles (10 km) high. To tell if there's any water, scientists will look for ice crystals and water vapor in this plume.

WE CHALLENGE YOU TO...

...modify a paper cup so it can zip down a line and drop a marble onto a target.

BRAINSTORM AND DESIGN

Think about how you might design a way to carry and launch a marble:

- How will you modify the cup so it can carry a marble down a zip line and also drop it onto a target?
- How will you remotely release the marble from the cup?
- When do you need to launch the marble so that it will hit the target?

BUILD

- 1. First, set up a zip line.** Tie 6 feet (1.8 m) of the smooth line to two objects (e.g., two chairs or a table and chair). Make sure it's stretched tight and that one end is about 20 inches (50 cm) below the other.
- 2. Next, figure out how to modify the cup to carry the marble down the zip line.** Will it travel inside the cup? Outside the cup on a platform? Underneath?
- 3. Then, add a remote release.** Decide how you will tip the cup at just the right instant to launch the marble toward the target.
- 4. Finally, clip the cup to the zip line.** Figure out how to hook the cup onto the zip line so it slides easily.

MATERIALS (per zip line)

- 9 feet (3m) of smooth line (e.g., fishing line or kite string)
- index card
- marble
- masking tape
- paper clip
- 1 medium-sized paper cup
- scissors
- target drawn on a piece of paper

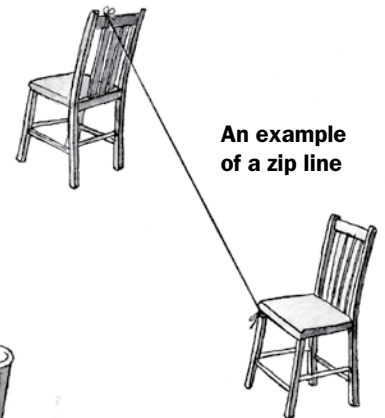

TEST, EVALUATE, AND REDESIGN

Ready for a test run? Place the target near the end of the zip line. Send down the cup and try to hit the target with the marble, using the remote release. How close did you get? See a way to improve your design? Engineers improve their designs by testing them. The steps they follow are called the design process. Try your idea and build an improved version. For example, if your cup:

- **goes slowly**—Check that the zip line is steep enough. Also, make sure the cup slides freely.



Materials to make a zip line, carrier, and target

- **can't keep the marble in**—Roll a small tube of tape to keep the marble from falling out accidentally. Also, adjust the tilt of the cup so it doesn't tip the marble out.
- **doesn't let the marble out**—Roll small tubes of tape and build a chute to funnel the marble toward the opening. If necessary, adjust the tilt of the cup so the marble can roll out more easily.
- **misses the target**—Since the marble is already moving forward along the zip line, it keeps moving forward as it falls. Make sure to take this forward motion into account as you choose a release point.

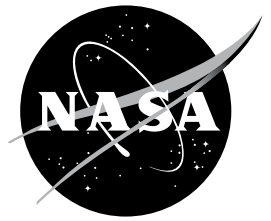

Check out NASA's moon missions at moon.msfc.nasa.gov.

“RUNNING AROUND IN THE WOODS HELPED ME THE MOST.”



As a kid, Tony Colaprete loved nature, ecology, and running around in the woods. He liked thinking about how, in one way or another, everything is connected. He brings that kind of thinking to his job as a

planetary scientist and as the top scientist for NASA's LCROSS mission. To learn about how other planets work, he builds computer models and designs instruments. These help him understand the many interesting connections between the different planets in our solar system. And the more Tony discovers, the more we learn about how our world—Earth—fits within our solar system.

NASA's Lunar Crater Observation and Sensing Satellite (LCROSS) will hit the moon, raising a tall plume of dust and gas and hopefully revealing the presence of water.

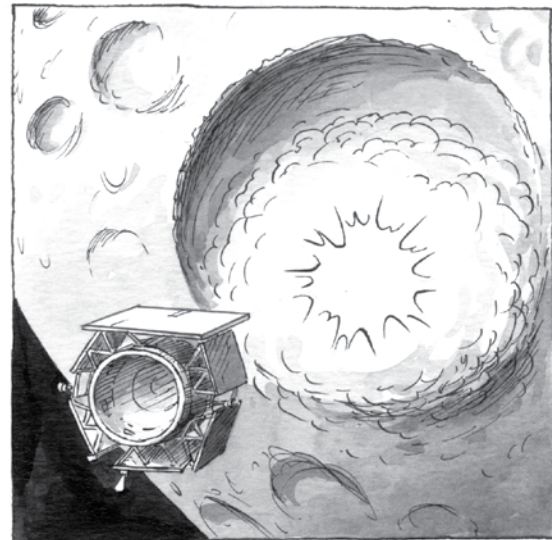
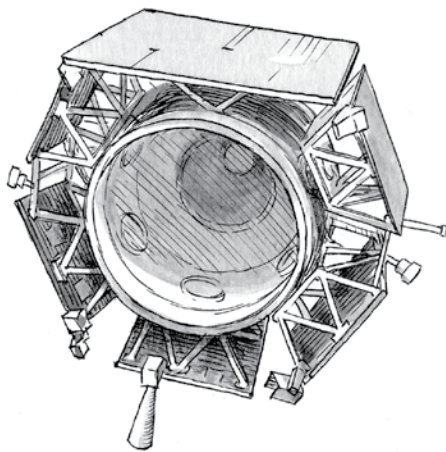

LOOK OUT BELOW!

NASA wants to make a deep hole on the moon to see if there's ice in the soil. But instead of beginning to dig at the surface, NASA is getting a head start. It will dig its hole at the bottom of a crater that's already about one mile (2 km) deep—and it won't dig, exactly. Instead, NASA will plunge a spacecraft named LCROSS into the crater. Scientists expect the collision will make a hole that's 80 ft. (24.4 m) across and 15 ft. (4.6 m) deep. The chances of finding ice at the bottom of this deep, dark, cold place are much better than finding it at the moon's surface, where the sun shines brightly on the soil, vaporizing any ice.

Watch **DESIGN SQUAD** on PBS or online at pbs.org/designsquad.



Major funding for *Design Squad* provided by



A private corporation funded by the American people



Education

Additional funding for *Design Squad* provided by



Design Squad is produced by WGBH Boston. *Design Squad*, AS BUILT ON TV, and associated logos are trademarks of WGBH. All rights reserved. This NASA/*Design Squad* challenge was produced through the support of the National Aeronautics and Space Administration (NASA).



For more information about NASA missions and educational programs, visit nasa.gov.